



# MANET sliding door system

## dimension sliding door track/glass fixing

with 4 fixing hole positions

holes in sliding door track  
for single point fixing

M 1:1

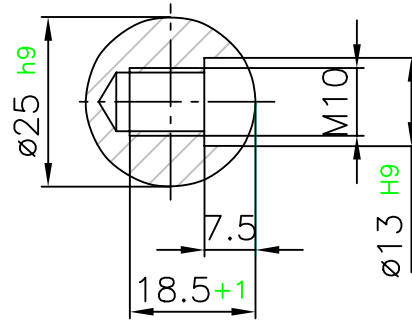
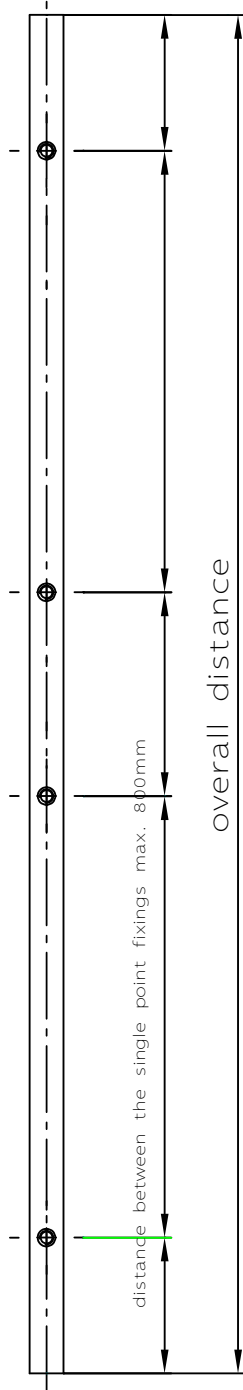

sliding door tracks are fixed with one solid single point fixing, the others are adjustable for alignment

drill holes angled with a tolerance of  $\pm 0,2$  to one another  
the ends of the track are machine faced and canted

max. tolerance of  $\pm 0,3$   
(from the first to the last drill hole)

Zielpfad (2D): P:\DWG1\21-045A.DWG  
Quellpfad (3D): F:\DATEN\8-21\951-999\82197001540.DWG

Order - No.: \_\_\_\_\_

Order: \_\_\_\_\_

